

AERONOBLE™ Polyurethane Air Inlet



Professional poultry ventilation solutions.

The highest quality air inlet and value added in ventilation design; offering our standard and complete product line as well as the design and manufacturer of client specific molds for their private label inlet.

As a leader in Polyurethane air inlets, we have the ability to offer a full solutions from concept to design to reality.

We stand behind our inlets with an industry leading warranty.

Noble Manufacturing Co., Limited has the right solution for you.

NA056-AS

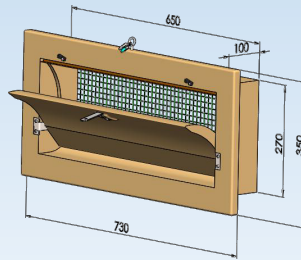

1

NA008-AS

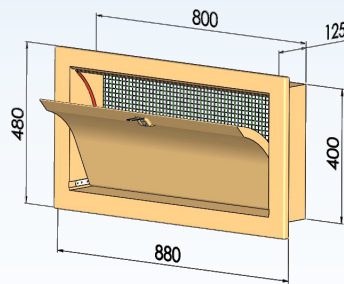

2

NA30021-AS

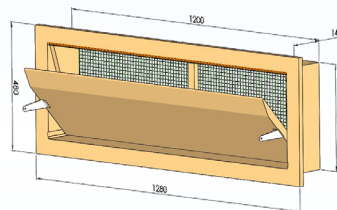

3

NA4J-0021-AS

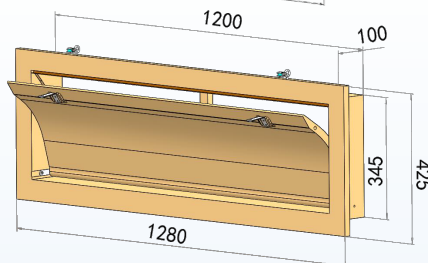

4

NA50051-AS

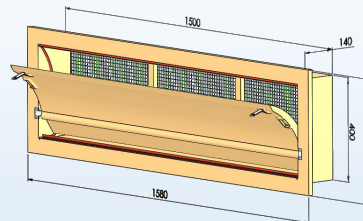

5

NA0012-AT

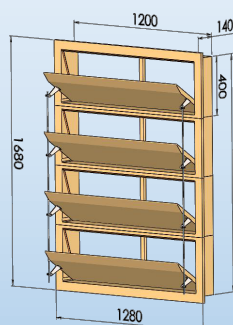

6

NA0051-AT

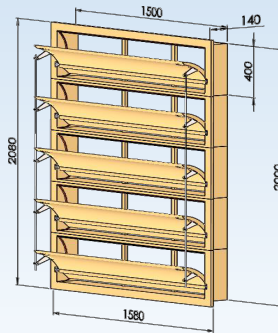

7

NA0055-AC

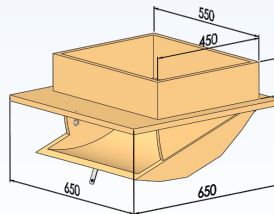

8

NAD-048-AC

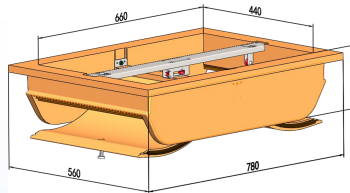

9

NAD-048-AC

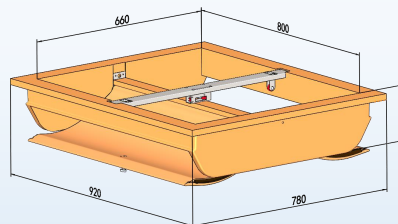

10

NA056-AS

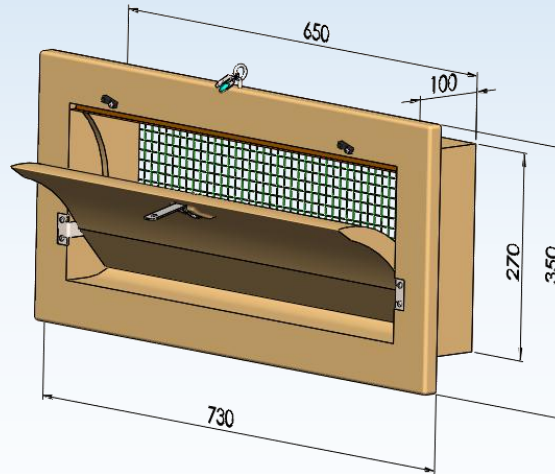

10pa	1450m ³ /h
20pa	1980m ³ /h
25pa	2150m ³ /h
Material	Polyurethane(PU)
Thermal insulation coefficient	0.022 W(m.k)
Installation size	650mm*270mm
Recommended hole size	660mm*280mm

NA008-AS

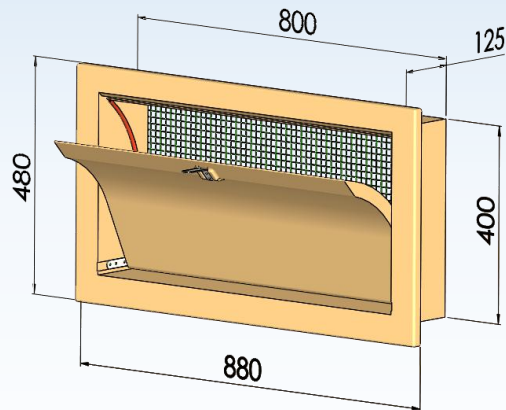

10pa	2050m ³ /h
20pa	3536m ³ /h
25pa	4265m ³ /h
Material	Polyurethane(PU)
Thermal insulation coefficient	0.022 W(m.k)
Rough Opening	800mm*400mm
Recommended hole size	810mm*410mm

NA30021-AS

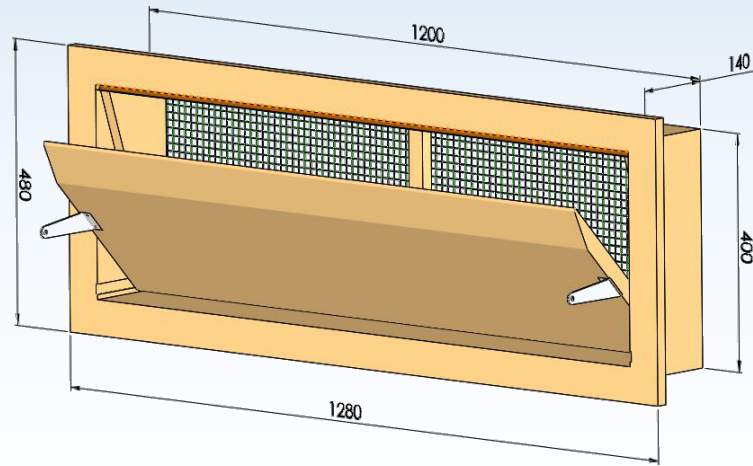

10pa	3850m ³ /h
20pa	5381m ³ /h
25pa	6532m ³ /h
Material	Polyurethane(PU)
Thermal insulation coefficient	0.022 W(m.k)
Rough Opening	1200mm*400mm
Recommended hole size	1210mm*410mm

NA4J-0021-AS

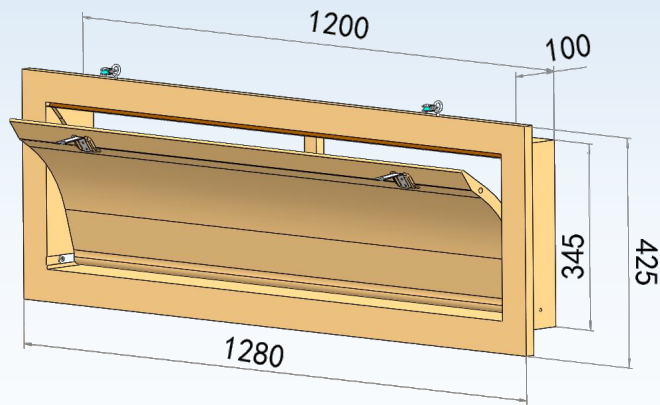

10pa	3320m ³ /h
20pa	4641m ³ /h
25pa	5633m ³ /h
Material	Polyurethane(PU)
Thermal insulation coefficient	0.022 W(m.k)
Rough Opening	1200mm*345mm
Recommended hole size	1210mm*355mm

NA50051-AS

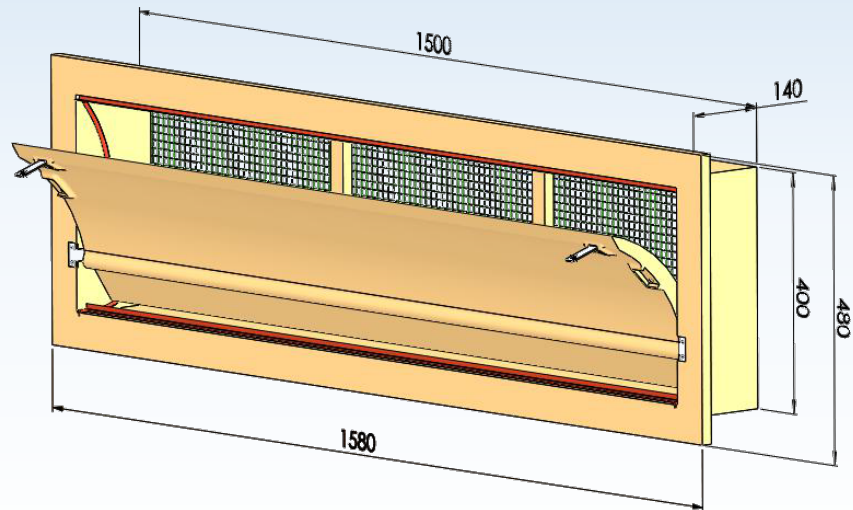

10pa	5800m ³ /h
20pa	7860m ³ /h
25pa	8750m ³ /h
Material	Polyurethane(PU)
Thermal insulation coefficient	0.022 W(m.k)
Rough Opening	1500mm*400mm
Recommended hole size	1510mm*410mm

NA0012-AT

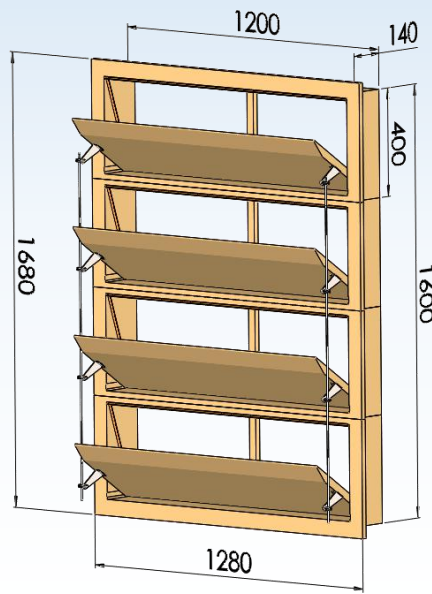
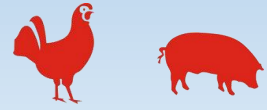

Number of layer	Rough Opening (mm)	Recommended hole size	Ventilation volume (10 pa)	Ventilation volume (20 pa)	Ventilation volume (25pa)
1	1200*400	1210*410	3,850 m ³ /h	5,381 m ³ /h	6,532 m ³ /h
2	1200*800	1210*810	7,700 m ³ /h	10,762 m ³ /h	13,064 m ³ /h
3	1200*1200	1210*1210	11,550 m ³ /h	16,143 m ³ /h	19,596 m ³ /h
4	1200*1600	1210*1610	15,400 m ³ /h	21,524 m ³ /h	26,128 m ³ /h
5	1200*2000	1210*2010	19,250 m ³ /h	26,905 m ³ /h	32,660 m ³ /h

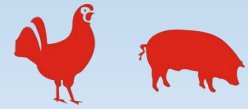

NA0051-AT

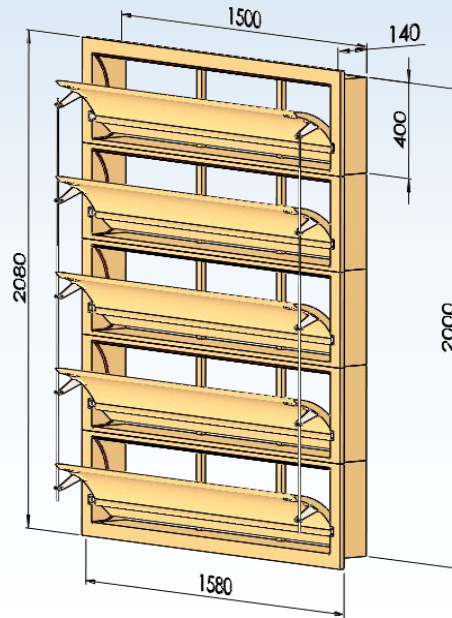

Number of layer	Rough Opening (mm)	Recommen- ded hole size	Ventilation volume (10 pa)	Ventilation volume (20 pa)	Ventilation volume (25pa)
1	1500*400	1510*410	5,800 m ³ /h	7,860 m ³ /h	8,750 m ³ /h
2	1500*800	1510*810	11,600 m ³ /h	15,720 m ³ /h	17,500 m ³ /h
3	1500*1200	1510*1210	17,400 m ³ /h	23,580 m ³ /h	26,250 m ³ /h
4	1500*1600	1510*1610	23,200 m ³ /h	31,440 m ³ /h	35,000 m ³ /h
5	1500*2000	1510*2010	29,000 m ³ /h	39,300 m ³ /h	43,750m ³ /h

NA0055-AC

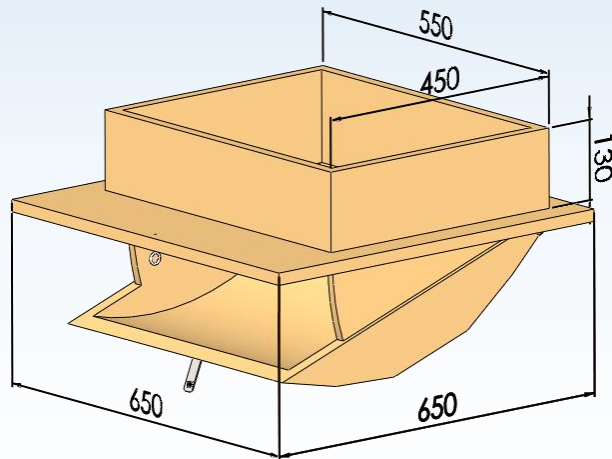

10pa	1823m ³ /h
20pa	2586m ³ /h
25pa	3060m ³ /h
Material	Polyurethane(PU)
Thermal insulation coefficient	0.022 W(m.k)
Rough Opening	550mm*450mm
Recommended hole size	560mm*460mm

NA048-AC

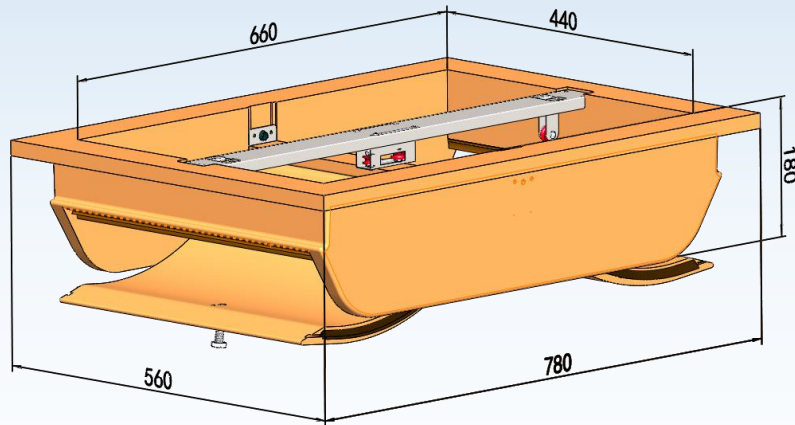

10pa	1539m ³ /h
20pa	2162m ³ /h
25pa	2614m ³ /h
Material	Polyurethane(PU)
Thermal insulation coefficient	0.022 W(m.k)
Rough Opening	480mm*700mm
Recommended hole size	490mm*710mm



NAD-048-AC

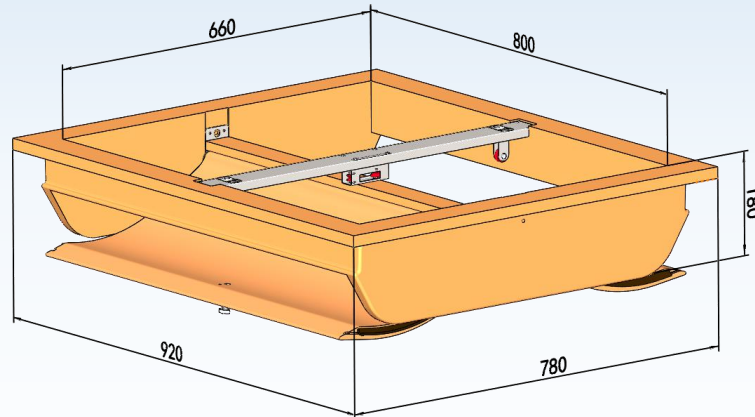

10pa	3078m ³ /h
20pa	4324m ³ /h
25pa	5227m ³ /h
Material	Polyurethane(PU)
Thermal insulation coefficient	0.022 W(m.k)
Rough Opening	840mm*700mm
Recommended hole size	850mm*710mm



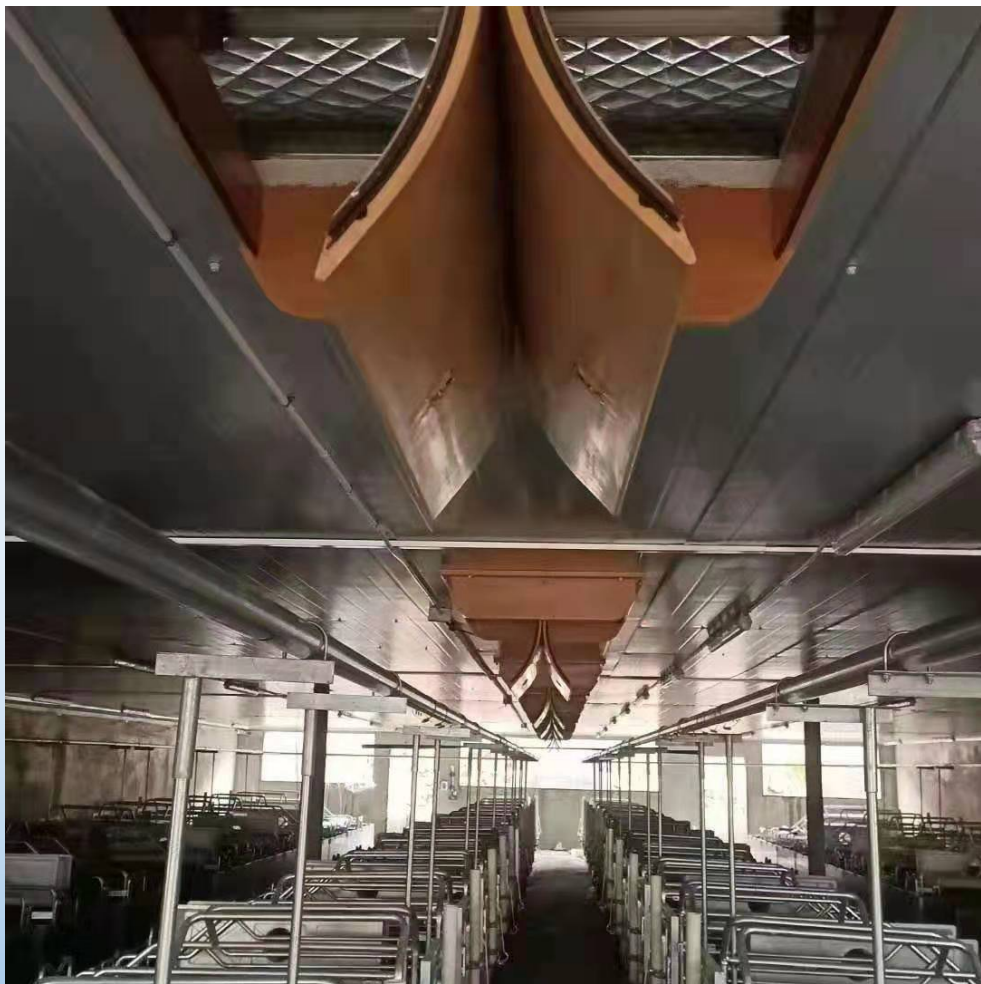







Noble Manufacturing Co., Limited

AERONOBLE™ 

128 Haibin avenue,

Chikan district, Zhanjian, China

Tel:+86-0759-3615380

Mob:+86-136-9420-5865

victoria@noblegz.com

<https://www.noble-mfg.com>